



P200-VHF-H-16

High Power RF Amplifiers and Accessories

200W VHF Band III TV Linear Pallet Amplifier

The **P200-VHF-H-16** is an integrated TV linear amplifier designed for the television integrator. Providing a minimum of 175W Pk sync linear power, the P200-VHF-H-16 is the perfect amplifier for any low band VHF transmitter. This cost effective building block makes a great IPA or can be combined in multiple arrays for high power PAs.

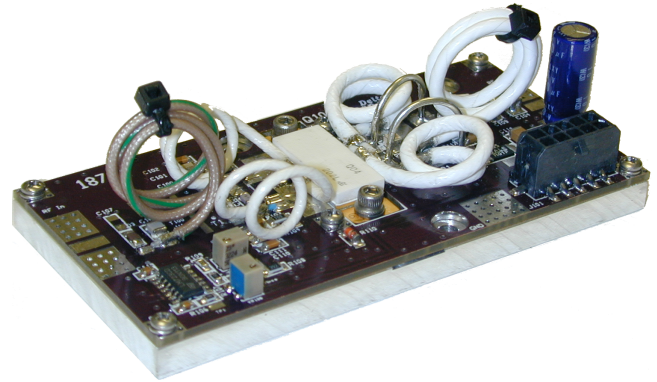

- No RF assembly or circuit tuning!
- 200 Watts of Output Power!
- 16dB typical gain at Channel 13!
- Combined **Video and Aural** at full rated power!
- Modular Construction for ease of Integration!

Specifications:

$V_{sup}=+28V_{dc}$, $I_{dg}=0.8A$, 170-230MHz

Parameter	Min	Typ	Max	Units
Power Out, P1dB		53		+dBm
Linear Power Out, Pk Sync <small>Full Field Red, NTSC-NA, IMD-54dBc</small>	175			Watts
Power Input, Pk Sync		5	8	Watts
Power Gain	15	16		dB
Drain Current <small>P_{out} = 200W Pk Sync</small>		10	11	A
Input VSWR		1.2:1	1.5:1	
Insertion Phase Variation <small>(unit to unit)</small>		±5		°
Power Gain Variation <small>(unit to unit)</small>		±1		dB
F2 Second Harmonic		-35		dBc
F3 Second Harmonic		-15		dBc
Baseplate Operating Temp	0		+70	°C
Physical Dimensions	2.0" x 4.0" x 1.5" / 5cm x 10cm x 4cm			

Absolute Maximum Ratings:

Parameter	Value	Units
Maximum Operating Voltage	+34.0	V DC
Stable Operating Voltage	+26.0 to +32.0	V DC
Maximum Bias Current <small>Factory set to 0.8A.</small>	3.0	A
Maximum Drain Current <small>Note - J100 connector rated for 20A maximum</small>	14	A
Maximum Input Power	40	+dBm
Load Mismatch Survival <small>At all phase angles with the base plate held at 40C and Id current limited to 12A, 2 seconds maximum</small>	5:1	
Storage Temperature	-40 to +105	°C
Maximum Operating Baseplate Temperature	+70	°C

Features Include:

- Temperature Compensated Bias
- Amplifier Disable
- Current Sense
- Connectorized Power and I/O

web <http://www.drft.com> • email : sales@drft.com • 1.775.DELTA RF • FAX 1.775.DELTA FX

Delta RF Technology, Inc. • 801 East Glendale Ave • Sparks • NV • 89431 • U S A

The specifications contained herein are subject to change without notice. Delta RF Technology, Inc. assumes no liability for the use of this information.

© Delta RF Technology, Inc., 2004. Rev 1.b 04/04



P200-VHF-H-16

High Power RF Amplifiers and Accessories

200W VHF Band III TV Linear Pallet Amplifier

Pin vs. Pout

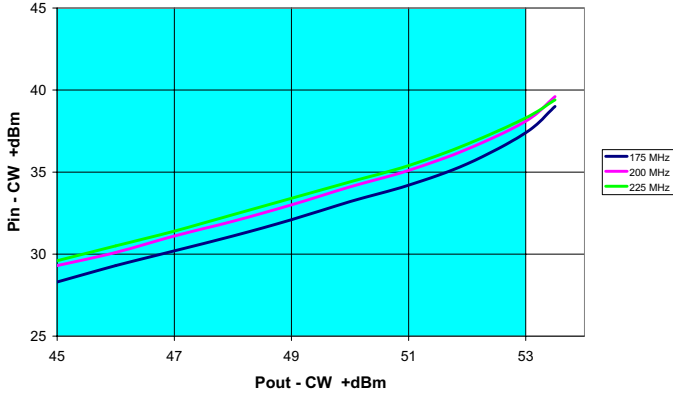

Gain Compression

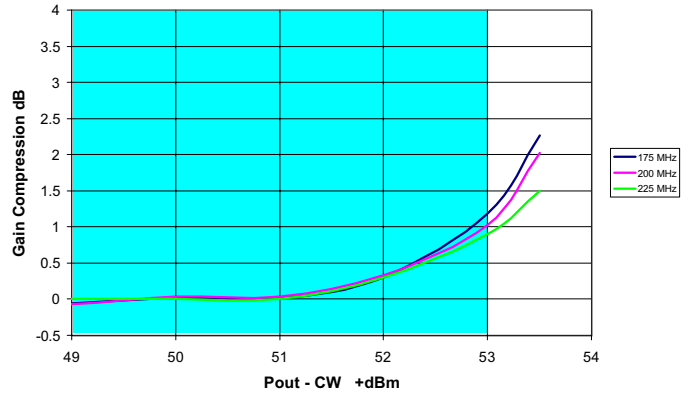

Shaded Area denotes recommended operating power level

Efficiency

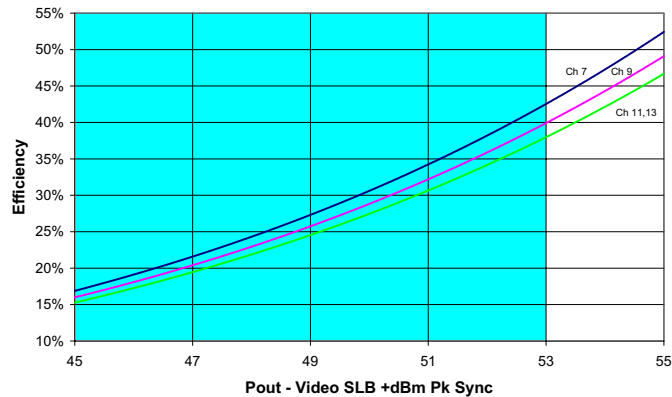



P200-VHF-H-16

High Power RF Amplifiers and Accessories

200W VHF Band III TV Linear Pallet Amplifier

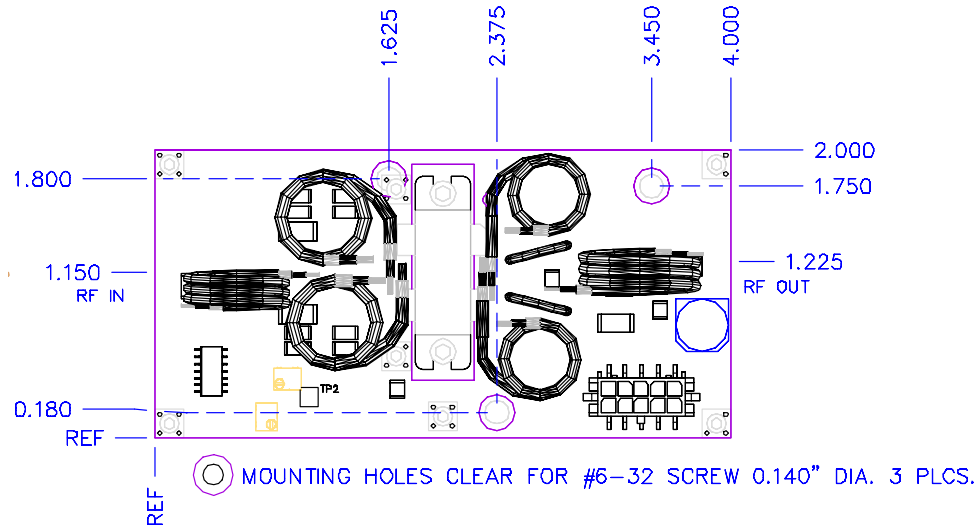

Tips for Mechanical Mounting:

- 1 All holes are clear for #6 Screw. Stainless Steel mounting hardware is recommended, grade 18-8 or better. A lock washer of same material should also be used.
- 2 Ensure mounting surface is flat to better than 0.003" / "
- 3 Use a thin layer of thermal compound on the backside of the PA - no more than 0.001" - 0.002" thickness!
- 4 Torque all screws to 10-12 in-lbs

Considerations for Mechanical Mounting:

- Considerations for proper thermal design include
- Total power dissipated = Total DC Power Consumed x (1-Efficiency)
- Ambient Airflow
- Thermal Resistance of Heat Sink



P200-VHF-H-16

High Power RF Amplifiers and Accessories

200W VHF Band III TV Linear Pallet Amplifier

Electrical Connections:

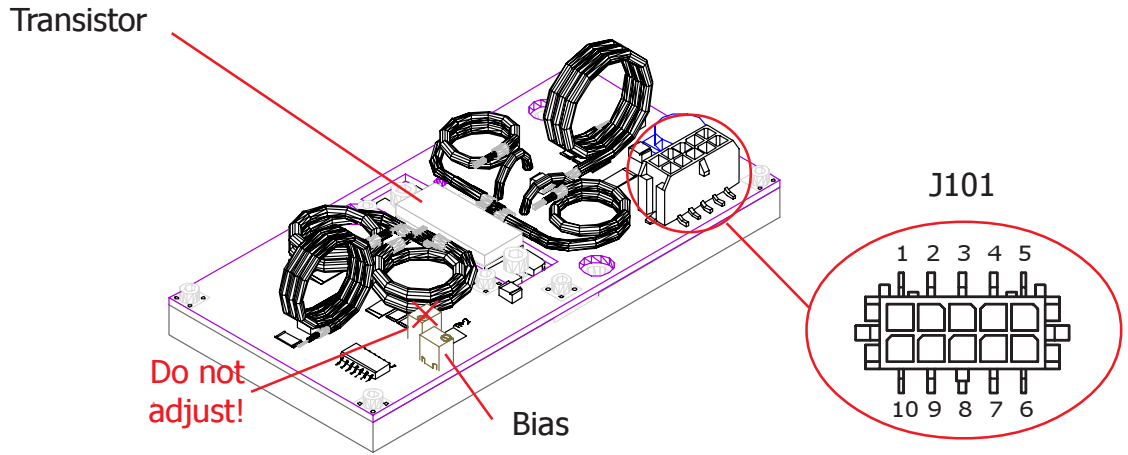

Power	J101-1	CURRENT	Current Sense
3.0mm Micro Connector: MOLEX #3025-1000	J101-2,3,8,9	GROUND	System Ground
MOLEX Pin #3030-0001, #3030-0007	J101-4,5	Vsup	+28 to +32 VDC
AMP Pin 1-794617-0	J101-6,7,10	N/C	No Connection
AMP Pin 794610, 794606			
-or-			
Solder directly to pad adjacent to connector			

Connections:

Connect amplifier to +Vsup and Ground using either 3.0mm modular 10-position plug (J101) or soldering directly to pad adjacent to connector. If using Single connection, 14 gauge wire is recommended, 14 gauge ground wire. 20 gauge wire is recommended for use in modular connector, and all power connections must be used! In all cases, use of teflon insulated wire is highly recommended.

Amplifier Startup

+Vsup should be applied to amplifier with no drive applied. The system must allow drain voltage to reach +26V minimum before applying drive or damage can result to the amplifier and void warranty. This typically takes between 2 - 10 seconds and should be verified by the system integrator. The amplifier may be disabled by applying ground to TP1, which is the solder pad to the left of bias pot. This point must be allowed to float for proper operation.

Bias Current:

Bias current is controlled via temperature compensated bias system that uses a hermetically sealed glass thermistor as reference. If excessive air is directed above the amplifier such that the thermistor is cooled below the temperature of the baseplate, this circuitry may not perform properly. Bias has been pre-set at the factory to 0.8A at +28.0V DC. This bias point has been selected to offer the optimum balance between IMD performance, efficiency, and gain. If the bias point is changed, take great care to set the same bias point on each transistor in your system, and not to exceed the bias maximum listed on page 1.

Fault Condition - Bad VSWR

Current sense J101-1 should be monitored for excessive current. The voltage difference between J100-1 to J100-4,5 is scaled 1A per 0.010 V. If the transistor experiences currents in excess of normal operation, a fault condition exists, and the amplifier should be disabled through TP1 or removing drain voltage. If current on the transistor drops to below 0.5A indicated, a fault condition exists, and the amplifier should be disabled through TP1 or by removing drain voltage.

Amplifier Shutdown

To prevent damage to amplifier and surrounding systems, bias and drive should be removed prior to powering down PA. This can be accomplished by grounding TP1 and removing drive then powering down PA, or simply removing drive and powering down PA.

Miscellaneous:

It is normal for the output transformers (flexible coax on the output of transistor) to get warm during operation. These components are rated for continuous operation in excess of 150°C. Placing noisy analog or digital systems, such as additional control circuitry, directly over the top of transistors or RF path can cause improper operation. Care should be taken to locate these components where they will not cause interference.